

8 7 6 5 4 3 2 1

Notes:
 1. Material Condition:
 2.

REVISIONS			
REV.	DESCRIPTION	DATE	APPROVED

Drawing for Reference Only
Measurements are approximate
and taken from worn out tracks

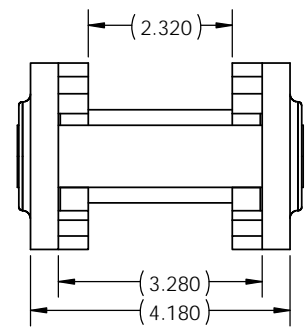
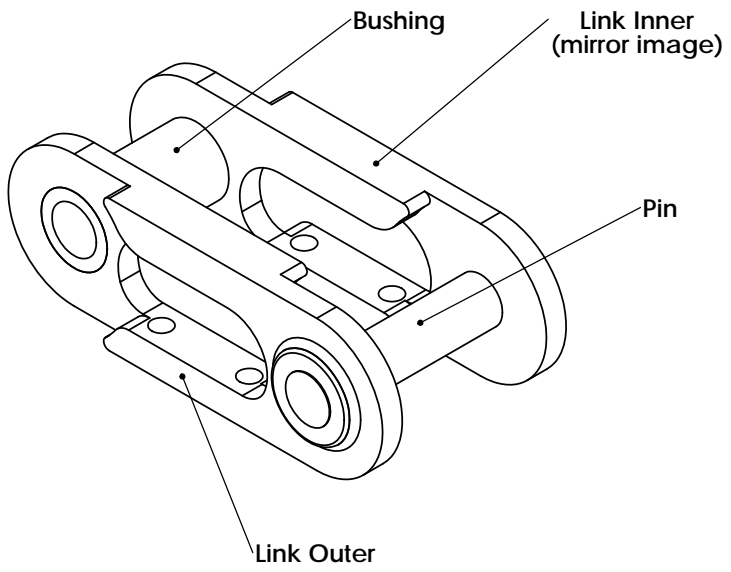
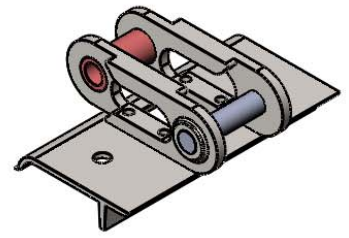

PROPRIETARY AND CONFIDENTIAL
 THE INFORMATION CONTAINED IN THIS DRAWING IS THE SOLE PROPERTY OF THE RANGE TOOL COMPANY. ANY REPRODUCTION IN PART OR AS A WHOLE WITHOUT THE WRITTEN PERMISSION OF THE RANGE TOOL COMPANY IS PROHIBITED.

		UNLESS OTHERWISE SPECIFIED:		NAME	DATE	THE RANGE TOOL COMPANY 310 NORTH BROADWAY PO BOX 713 GILBERT MN 55741 Part Name T340 Track Link Assembly
		DIMENSIONS ARE IN INCHES	DRAWN		8/31/2014	
		TOLERANCES:	CHECKED		8/31/2014	
		FRACTIONAL ±	ENG APPR.			
		ANGULAR: MACH ± BEND ±	MFG APPR.			
		TWO PLACE DECIMAL ± 010	Q.A.			SIZE Part No. REV
		THREE PLACE DECIMAL ± 005				SCALE: 1:5 WEIGHT: SHEET 1 OF 3
		INTERPRET GEOMETRIC TOLERANCING PER:				
		MATERIAL				
		FINISH				
NEXT ASSY	USED ON					
		APPLICATION				
		DO NOT SCALE DRAWING				

8 7 6 5 4 3 2 1

8 7 6 5 4 3 2 1

Notes:
 1. Material Condition:
 2.

REVISIONS			
REV.	DESCRIPTION	DATE	APPROVED

**Drawing for Reference Only
 Measurements are approximate
 and taken from worn out tracks**

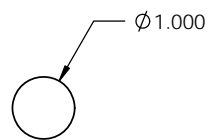
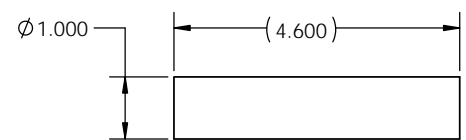
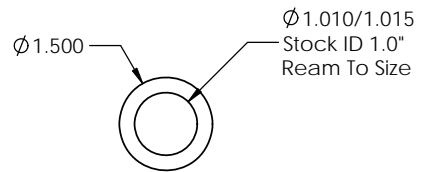
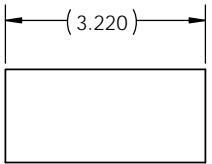
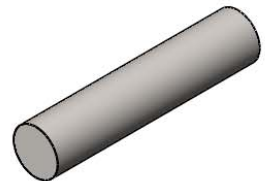
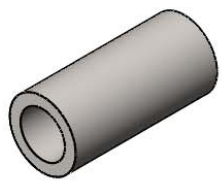

Pins, Busings and Bore holes in Links not to exact original Specs. Modified Sizes to be compatible with off the shelf material.

PROPRIETARY AND CONFIDENTIAL
 THE INFORMATION CONTAINED IN THIS DRAWING IS THE SOLE PROPERTY OF THE RANGE TOOL COMPANY. ANY REPRODUCTION IN PART OR AS A WHOLE WITHOUT THE WRITTEN PERMISSION OF THE RANGE TOOL COMPANY IS PROHIBITED.

		UNLESS OTHERWISE SPECIFIED:	NAME	DATE	THE RANGE TOOL COMPANY 310 NORTH BROADWAY PO BOX 713 GILBERT MN 55741 Part Name T340 Track Link Assembly
		DIMENSIONS ARE IN INCHES	DRAWN	8/31/2014	
		TOLERANCES:	CHECKED	8/31/2014	
		FRACTIONAL ±	ENG APPR.		
		ANGULAR: MACH ± BEND ±	MFG APPR.		
		TWO PLACE DECIMAL ± .010	Q.A.		
		THREE PLACE DECIMAL ± .005	COMMENTS:		
		INTERPRET GEOMETRIC TOLERANCING PER:			
		MATERIAL:			
		FINISH:			
NEXT ASSY	USED ON				SIZE B Part No. T340 Pin Bushing REV
APPLICATION	DO NOT SCALE DRAWING				SCALE: 1:5 WEIGHT: SHEET 3 OF 3

8 7 6 5 4 3 2 1